

EXU and EXH Technical Data Low Lift Pallet Trucks

[EXU 16/Li-Ion](#)

[EXU 18/Li-Ion](#)

[EXU 20/Li-Ion](#)

[EXU 22](#)

[EXH 25/Li-Ion](#)

[EXH 30/Li-Ion](#)

[EXU-H 18](#)

[EXU-H 20/Li-Ion](#)





		EXU 16/Li-Ion	EXU 18/Li-Ion	EXU 20/Li-Ion	EXU 22	EXH 25/Li-Ion	EXH 30/Li-Ion	EXU-H 18	EXU-H 20/Li-Ion				
Features	1.1	Manufacturer		STILL	STILL	STILL	STILL	STILL	STILL				
	1.2	Manufacturer's model designation		EXU 16/Li-Ion	EXU 18/Li-Ion	EXU 20/Li-Ion	EXU 22	EXH 25/Li-Ion	EXH 30/Li-Ion	EXU-H 18	EXU-H 20/Li-Ion		
	1.3	Drive		Electric	Electric	Electric	Electric	Electric	Electric	Electric			
	1.4	Operation		Pedestrian truck	Pedestrian truck	Pedestrian truck	Pedestrian truck	Pedestrian truck	Pedestrian truck	Pedestrian truck			
	1.5	Capacity/load	Q	kg	1600	1800	2000	2200	2500	3000	800/1800	800/2000	
	1.6	Load centre distance	c	mm	600	600	600	600	600	600	600	600	
	1.8	Load distance	x	mm	963/883 ¹	963/883 ¹	963/883 ¹	963/883 ¹	975/895 ¹	975/895 ¹	950/890 ¹	950/890 ¹	
	1.9	Wheel base	y	mm	1304/1228 ¹	1304/1228 ¹	1381/1301 ¹	1449/1370 ¹	1453/1373 ¹	1453/1373 ¹	1404/1338 ¹	1404/1338 ¹	
	2.1	Service weight incl. battery		kg	430/357 ²	430/357 ²	495/385 ³	606	819	819	558	603	
Weights	2.2	Axle weight, laden	drive end/load end	kg	680/1350	746/1542	789/1699	908/1833	1428/1927	1572/2246	822/1539	937/1664	
	2.3	Axle weight, unladen	drive end/load end	kg	384/104	384/104	384/104	384/104	662/157	662/157	411/145	458/145	
	3.1	Tyres			Polyurethane	Polyurethane	Polyurethane	Polyurethane	Polyurethane	Polyurethane	Polyurethane	Polyurethane	
Tyres/chassis	3.2	Tyre size	drive end	mm	Ø 230 x 75	Ø 230 x 75	Ø 230 x 75	Ø 230 x 75	Ø 230 x 90	Ø 230 x 90	Ø 230 x 75	Ø 230 x 75	
	3.3	Tyre size	load end	mm	Ø 85 x 105	Ø 85 x 100	Ø 85 x 100	Ø 85 x 100	Ø 85 x 85 (85 x 60) ⁴	Ø 85 x 85 (85 x 60) ⁴	Ø 85 x 90 (Ø 85 x 65) ⁴	Ø 85 x 90 (Ø 85 x 65) ⁴	
	3.4	Support roller size		mm	Ø 125 x 40	Ø 125 x 40	Ø 125 x 40	Ø 125 x 40	Ø 2x 125 x 60	Ø 2x 125 x 60	2x Ø 125 x 40	2x Ø 125 x 40	
	3.5	Number of wheels (x = driven)	drive end/load end		1x + 2/2	1x + 2/4 ⁴	1x + 2/4 ⁴	1x + 2/4 ⁴	1x + 2/2 (1x + 2/4 ⁴)	1x + 2/2 (1x + 2/4 ⁴)	1x + 2/4 ⁴	1x + 2/4 ⁴	
	3.6	Tread width	drive end/load end	b ₁₀ /b ₁₁	mm	482/395	482/395	482/395	482/395	502/380	502/380	482/380 (340)	482/380 (340)
	4.4	Lift		h ₃	mm	130	130	130	130	125	125	550	550
Basic dimensions	4.9	Drawbar height in driving position	min./max.	h ₁₄	mm	740/1250	740/1250	740/1250	740/1250	740/1230	740/1230	720/1240	720/1240
	4.15	Fork height lowered		h ₁₃	mm	85	85	85	85	86	86	85	85
	4.19	Total length		l ₁	mm	1660	1660	1730	1820	1855	1855	1807	1882
	4.20	Length including fork backs		l ₂	mm	510	510	580	670	705 ⁵	705 ⁵	617	692
	4.21	Total width		b ₁ /b ₂	mm	720	720	720	720	720	720	720	720
	4.22	Fork dimensions	DIN ISO 2331	s/e/l	mm	55/165/1150	55/165/1150	55/165/1150	55/165/1150	55/165/1150	55/165/1150	50/180/1190	50/180/1190
	4.25	Overall fork width		b ₅	mm	520/560/680	520/560/680	520/560/680	520/560/680	520/560/680	520/560/680	560 (520)	560 (520)
	4.32	Ground clearance, centre of wheel base		m ₂	mm	36/166	36/166	36/166	36/166	30	30	20/145	20/145
	4.34.1	Working aisle width with 1000 x 1200 pallet crossways		A _{st}	mm	2314 ¹ /2288	2314 ¹ /2288	2364 ¹ /2343	2424 ¹ /2378	2514/2481 ^{1,5}	2514/2481 ^{1,5}	2405/2374 ¹	2408/2449 ¹
	4.34.2	Working aisle width with 800 x 1200 pallet lengthways		A _{st}	mm	2225 ¹ /2206	2225 ¹ /2206	2275 ¹ /2261	2335 ¹ /2296	2424/2399 ^{1,5}	2424/2399 ^{1,5}	2317/2292 ¹	2392/2367 ¹
	4.35	Turning radius		W _a	mm	1560/1495 ¹	1560/1495 ¹	1610/1550 ¹	1670/1585 ¹	1765/1695 ^{1,5}	1765/1695 ^{1,5}	1645/1585 ¹	1720/1660 ¹
	Performance data	5.1	Driving speed	laden/unladen	km/h	6/6	6/6	6/6	6/6	6/6	6/6	6/6	6/6
5.2		Lifting speed	laden/unladen	m/s	0.040/0.060	0.040/0.060	0.040/0.060	0.034/0.043	0.028/0.036	0.026/0.036	0.115/0.184	0.115/0.184	
5.3		Lowering speed	laden/unladen	m/s	0.071/0.065	0.071/0.065	0.071/0.065	0.070/0.063	0.066/0.072	0.065/0.072	0.326/0.130	0.326/0.130	
5.8		Max. gradeability kB 5	laden/unladen	%	14/24	13/24	11/24	10/24	12/20	10/20	12/24	10/24	
5.9		Acceleration speed (to 10 m)	laden/unladen	s	7.58/6.50	7.65/6.50	8.04/6.50	8.04/6.50	7.4/6.56	7.7/6.56	8.45/7.10	8.45/7.10	
5.10		Service brake				Electromagnetic	Electromagnetic	Electromagnetic	Electromagnetic	Electromagnetic	Electromagnetic	Electromagnetic	Electromagnetic
Electric engine	6.1	Drive motor, rating S2 60 min.		kW	1.2	1.2	1.2	1.2	1.5	1.5	1.2	1.2	
	6.2	Lift motor, rating at S3 15%		kW	1.0	1.0	1.2	1.4	1.5	1.5	1.2	1.2	
	6.3	Battery according to DIN 43531/35/36 A, B, C, no				British Standard	British Standard	2PzS	2PzS	2PzS	British Standard	2PzS	
	6.4	Battery voltage/rated capacity K _s		V/Ah	24/150 Li-Ion: 24/82	24/150 Li-Ion: 24/82	24/250 Li-Ion: 24/205	24/375	24/250 Li-Ion: 24/205	24/250 Li-Ion: 24/205	24/150	24/250 Li-Ion: 24/82	
	6.5	Battery weight +5% (depending on manufacturer)		kg	141/56 ²	141/56 ²	213	301	290	290	144	191/56 ^{2,3}	
	6.6	Energy consumption according to VDI cycle		kWh/h	0.38	0.38	0.38	0.38	0.48	0.57	0.38	0.38	
Misc.	8.1	Transmission control			AC control	AC control	AC control	AC control	AC control	AC control	AC control	AC control	
	8.4	Noise level (at operator's ear)		dB(A)	68.7	68.7	68.7	68.7	60	60	62.0	62.0	

¹ Initial lift raised
² Li-Ion; +15 kg for 164 Ah Li-Ion battery
³ Li-Ion; +41 kg for 410 Ah Li-Ion battery
⁴ Tandem load rollers
⁵ +75 mm with 3PzS; +150 mm with 4PzS

Optional operating platform (pedestrian/standing)

		EXU 20 S	EXU 22 S			
1.2	Manufacturer's model designation					
1.4	Operation	Standing truck	Standing truck			
2.1	Service weight incl. battery	kg	610	659		
2.2	Axle weight, laden	drive end/load end	kg	896/1689	934/1851	
2.3	Axle weight, unladen	drive end/load end	kg	384/104	384/104	
4.9	Drawbar height in driving position	min./max.	h ₁₄	mm	740/1250	740/1250
4.19	Total length	pedestrian/static	l ₁	mm	1890/2270 ¹	1980/2360 ¹
4.20	Length including fork backs	pedestrian/static	l ₂	mm	740/1140 ¹	830/1210 ¹
4.34.1	Working aisle width with 1000 x 1200 pallet crossways	pedestrian/static	A _{st}	mm	1987 ¹ /2162	2078 ¹ /2253
4.34.2	Working aisle width with 800 x 1200 pallet lengthways	pedestrian/static	A _{st}	mm	2037 ¹ /2212	2128 ¹ /2303
4.35	Turning radius/initial lift lowered	pedestrian/static	W _a	mm	1600 ¹ /1775	1690 ¹ /1865
	Turning radius/initial lift raised	pedestrian/static	W _a	mm	1520/1695 ¹	1610/1785 ¹
5.1	Driving speed	laden/unladen	km/h	6/6	6/6	

¹ Initial lift raised

EXU Low Lift Pallet Truck

Technical Drawings

A = braking
B = driving

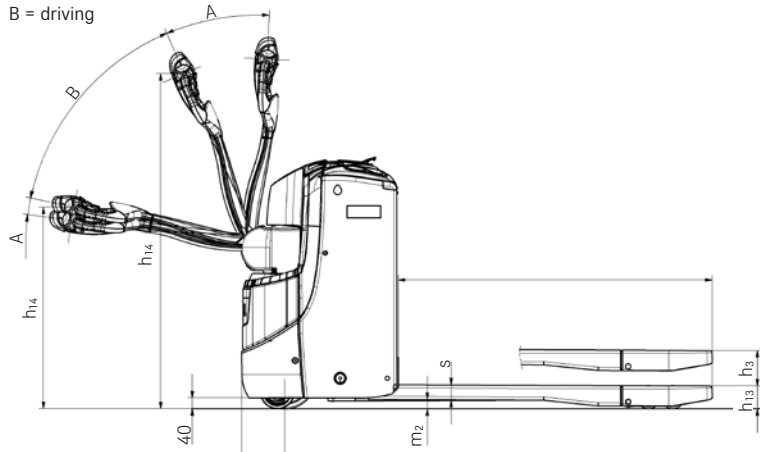

Side view EXU

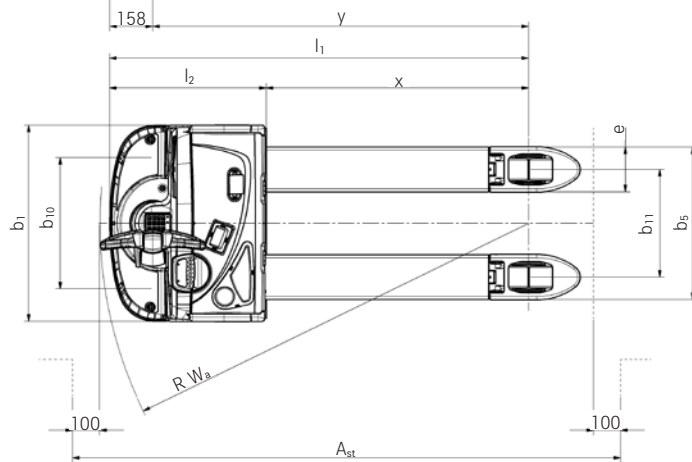

Top view EXU

A = braking
B = driving

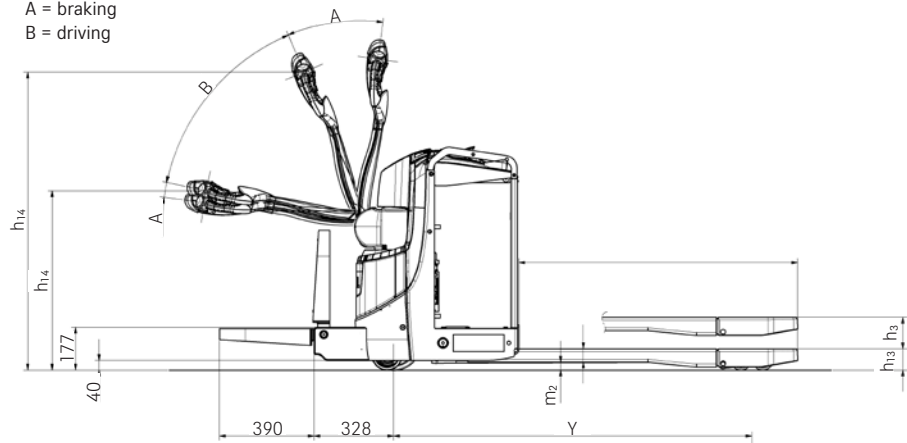

Side view EXU with optional operating platform

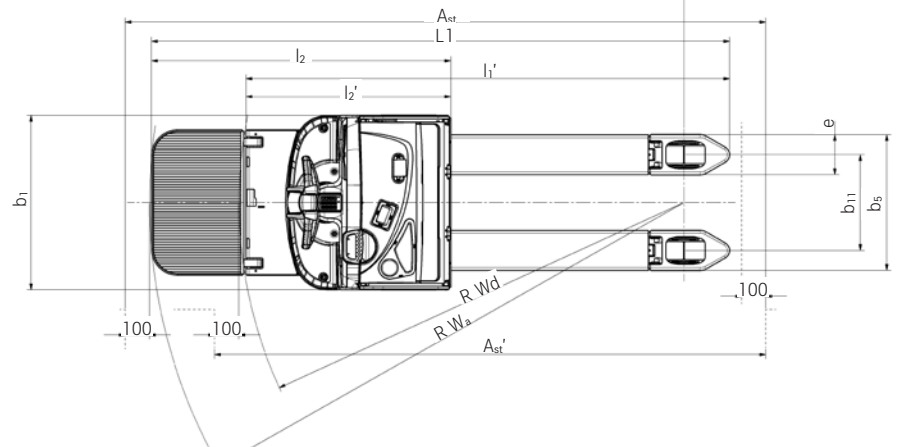

Top view EXU with optional operating platform

EXH Low Lift Pallet Truck

Technical Drawings

A = braking
B = driving

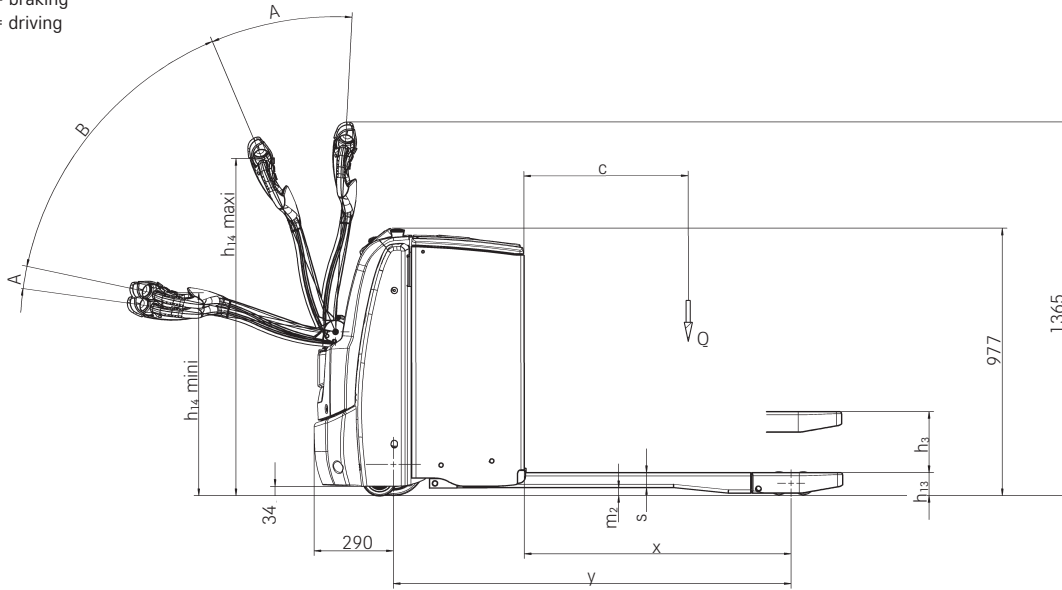

Side view EXH

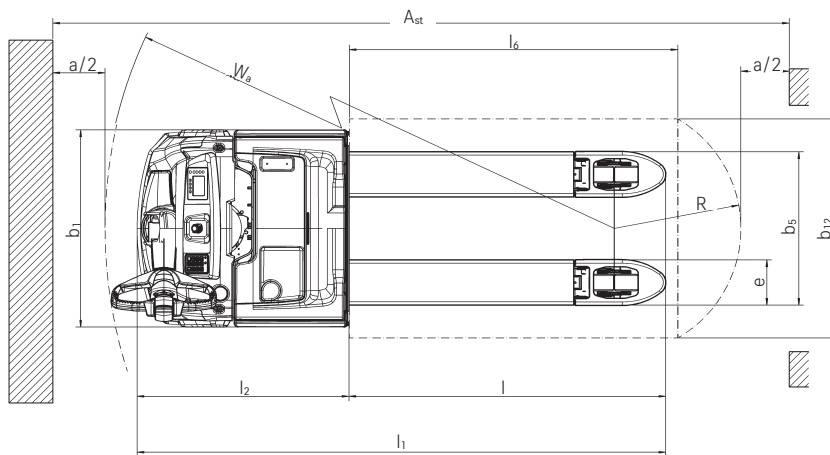

Top view EXH

EXU Low Lift Pallet Truck
Detailed Photos

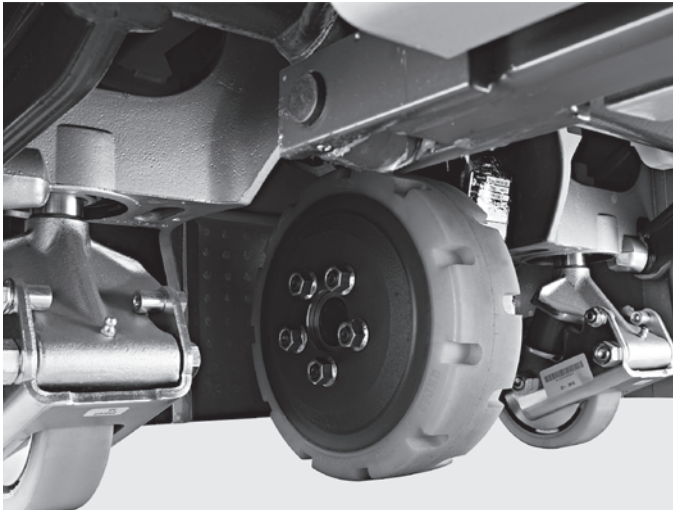

Robust chassis and hydraulic support wheels for powerful movement on ramps



Optimum view of the fork tips for fast threading into the pallet



Maximum availability due to lateral battery change

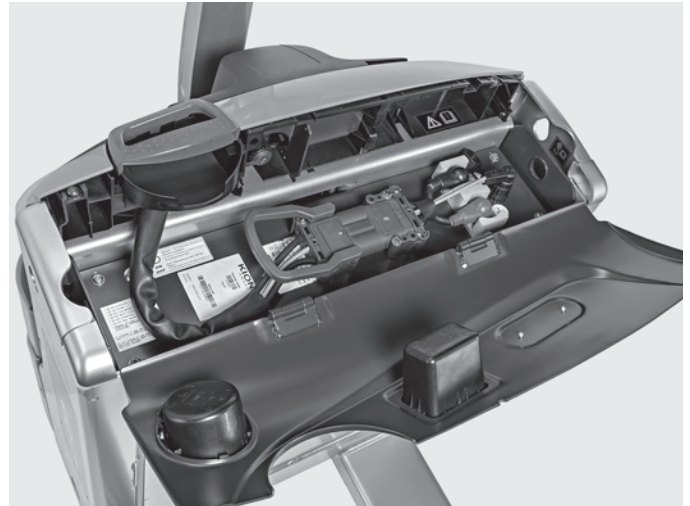

Quick charging of the batteries as well as interim charging due to Li-Ion technology

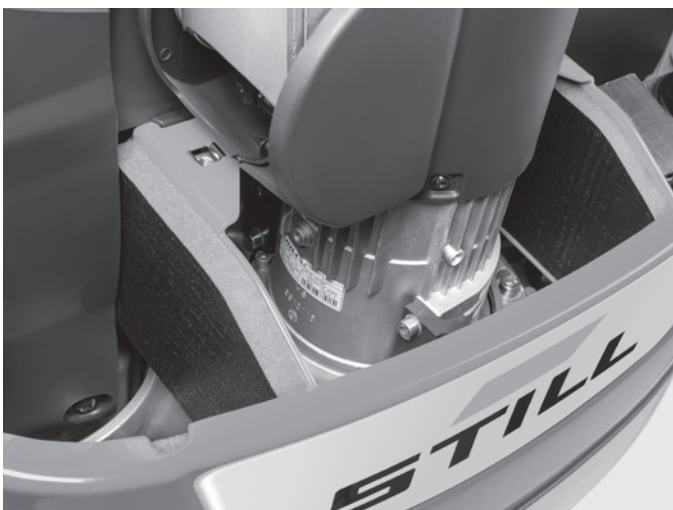

Almost soundless on the road thanks to the noise-reducing design with insulated interior and special load rollers



Access control also available via PIN code

EXU/EXH Low Lift Pallet Trucks
Detailed Photos



Fatigue-free operation thanks to additional lift from EXU-H



The autolift function provides perfect ergonomics by automatically lifting or lowering of the forks



Top performance thanks to a load capacity of up to 3,000 kg



Maximum manoeuvrability due to the electrical steering unit



Always available with Li-Ion technology and battery capacities of up to 500 Ah



Maximum safety when loading and unloading lorries thanks to safety and working lights

EXU/EXH Low Lift Pallet Trucks
Compact all-rounder for challenging applications



EXU/EXH Low Lift Pallet Trucks

Compact all-rounder for challenging applications

Always safe on the move due to OptiSpeed: speed adapts to the tiller angle

Maximum performance due to powerful, reliable and low maintenance rotary current drive

Always available due to lateral battery change and Li-Ion technology



EXU

Are you looking for a powerful low lift pallet truck for transporting loads of up to 2,200 kg across short distances? A warehouse assistant which can be manoeuvred precisely and safely even in confined spaces? Then you should take a look at the EXU! Thanks to its compact size, it is optimally suited for locations with limited space – from narrow warehouse gangways to loading and unloading lorries and working in supermarket aisles. Intelligent: the unique OptiSpeed tiller automatically adapts the speed of the forklift truck to the tiller angle, thus ensuring that goods are transported safely and quickly. Plus, with the 'ECO' and 'BOOST' driving programmes, you can choose between

maximum output and optimum efficiency at the press of a button. Do you not only want to transport goods but also to pick them in a particularly health-friendly way? The EXU-H model is equipped with a variably adjustable working height of up to 760 mm which guarantees an ergonomically optimum body position for all operators. The auto-lift function option provides even more comfort – a sensor detects the upper edge of the loaded goods and automatically adapts the working height. If another layer of goods is added or removed, the loading forks move up or down a fraction by themselves.

Highest turnover efficiency due to a lifting capacity of up to 3,000 kg

Best manoeuvrability and ergonomics due to electric steering and OptiSpeed tiller

Always available due to Li-Ion technology and battery capacities of up to 500 Ah



EXH

Never has the transportation of loads of up to 3,000 kg been this easy and ergonomic at the same time as with the EXH. Loads can be easily and precisely transported to their destination thanks to the electrical steering unit. The EXH is ideally suited for the horizontal transport of heavy loads or the loading and unloading of lorries. With the specially suspended support wheels, the EXH can move over ramps and uneven grounds without any problems. The BOOST driving programme ensures maximum turnover efficiency. Want to save energy with the press of a button? No problem. The EXH is equipped with an ECO driving

programme as well as the Blue-Q mode for maximum performance paired with simultaneous energy efficiency. With the colour display you have all the important information in sight at all times: battery status, operating hours and the time. The EXH is ready for use around the clock as the Li-Ion technology allows for quick charging as well as interim charging. Furthermore, the maximum battery capacity of up to 500 Ah and the lateral battery change guarantee maximum availability of the EXH, even in multi-shift operation.

EXU/EXH Low Lift Pallet Trucks Extensive Equipment

Power

- Top performance thanks to a lifting capacity of up to 3,000 kg
- High handling capacity: powerful, reliable and low-maintenance electrical drive and steering motor
- Battery capacity of up to 500 Ah and lateral battery change available as well as Li-Ion battery, which concentrates a large amount of energy and allows for easy interim charging
- The right driving programme for all situations: select maximum handling performance or maximum efficiency: ECO, BOOST or Blue-Q
- Comfortable on the ramp: the support wheels guarantee optimum traction and enable powerful movement on ramps

Precision

- Fatigue-free operation: precise and intuitive electrical steering unit of the EXH
- Best views for precise operation: clear view of the tips of the forks and centrally mounted tiller
- Both left- and right-handed users can intuitively operate all driving, lifting and lowering functions
- Reliable, even in narrow spaces: compact dimensions and high manoeuvrability
- Precise operation even in the most confined spaces with the creep speed function option
- All important information at a glance with the EXH colour display

Ergonomics

- Ergonomic and intuitive operation: driving, lifting and steering processes can be simultaneously controlled by left- or right-handed operators using just one hand
- Battery changing made easy: lateral battery change option for high availability at highest safety
- Work made easier: easy to operate, ergonomically shaped STILL tiller head

Compactness

- High pallet reloading rate: compact size allows for quick and safe operation
- Additional storage space for goods: copes with narrow aisles thanks to its compact dimensions and high manoeuvrability
- The optional built-in charger enables flexible and decentralised charging of the truck

Safety

- The deep-drawn truck frame protects the feet of operators and others in public areas
- Safety as standard: OptiSpeed tiller adapts speed automatically depending on distance between the operator and the truck
- Safe around corners: curve speed control of the EXH automatically adapts speed to the steering angle when cornering
- Safety in confined spaces: curved tiller shape protects the driver from getting trapped in front
- Accidental roll-back eliminated: automatic stop function also on ramps

Environmental Responsibility

- Low operating costs: low energy consumption and long maintenance intervals
- Blue-Q efficiency mode allows energy savings of up to 7 percent at the press of a button, with no loss of performance
- Applied environmental awareness: 95 per cent of the parts are recyclable
- Very low noise emission due to extremely quiet drive and lifting motor
- ECO driving programme: maximum energy efficiency at the touch of a button

EXU/EXH Low Lift Pallet Trucks Equipment Variants



	EXU 16	EXU 18	EXU 20	EXU 22	EXH 25	EXH 30	EXU-H 18	EXU-H 20
General	Minimised noise version: PIEK certified	○	○	—	—	—	○	○
	Two driving programs: ECO and BOOST	●	●	●	●	●	●	●
	Blue-Q driving programme	—	—	—	—	●	●	—
	Easy-grip tiller for left- and right-handed operators	●	●	●	●	●	●	●
	Electrical steering unit	—	—	—	—	●	●	—
	Low-maintenance rotary current drive	●	●	●	●	●	●	●
	Folding stand-on platform	—	—	○	○	—	—	○
	Various fork lengths	○	○	○	○	○	○	○
	Cold store variant	○	○	○	○	○	○	○
	Adjustable DIN-A4 writing pad	○	○	○	○	○	○	○
Tyres	Drive wheel tyres, polyurethane	●	●	●	●	●	●	●
	Drive wheel tyres, polyurethane, profiled	○	○	○	○	○	○	○
	Drive wheel tyres, polyurethane, soft	○	○	○	○	—	—	○
	Drive wheel tyres, polyurethane, soft, natural-coloured	○	○	○	○	○	○	○
	Drive wheel tyres, polyurethane, soft, natural-coloured, profiled	○	○	○	○	—	—	○
	Drive wheel tyres, polyurethane, soft, profiled	○	○	○	○	—	—	○
	Drive wheel tyres, solid rubber	—	—	—	—	○	○	—
	Drive wheel tyres, solid rubber, profiled	—	—	—	—	○	○	—
	Load roller tyres, polyurethane, single	●	○	○	○	●	●	—
	Load roller tyres, polyurethane, tandem	●	●	●	●	○	○	—
Safety	Load roller tyres, polyurethane, single greased axes and lifting links	○	○	○	○	—	—	—
	Load roller tyres, polyurethane, tandem greased axes and lifting links	○	○	○	○	○	○	—
	OptiSpeed: controls the speed in accordance with the tiller angle	●	●	●	●	●	●	●
	Creep speed function and lifting/lowering with vertical tiller	○	○	○	○	○	○	○
	FleetManager: access authorisation, shock detection, reports	○	○	○	○	○	○	○
	PIN code access	○	○	○	○	○	○	○
	Accessories bracket on the load end	○	○	○	○	○	○	○
	Load backrest	○	○	○	○	○	○	○
	Load end working lights	—	—	—	—	○	○	—
	SafetyLight, load end	—	—	—	—	○	○	—
Battery system	Battery compartment for 134-150 Ah battery, for changing batteries with a crane	●	●	—	—	—	●	—
	Battery compartment for 200-250 Ah battery, for changing batteries with a crane	○	○	●	—	●	●	●
	Battery compartment for 200-250 Ah batteries for lateral battery change with chassis	—	○	○	—	○	○	○
	Battery compartment for 300-375 Ah battery, for changing batteries with a crane	—	—	—	●	○	○	—
	Battery compartment for 300-375 Ah batteries for lateral battery change with changing rack	—	—	—	○	○	○	—
	Battery compartment for 400-500 Ah battery, for changing batteries with a crane	—	—	—	—	○	○	—
	Battery compartment for 400-500 Ah batteries for lateral battery change with changing rack	—	—	—	—	○	○	—
	Built-in charger for wet-cell batteries/gel batteries	○	○	○	○	○	○	○
	82 Ah STILL Li-ion battery	○	○	—	—	—	—	○
	164 Ah STILL Li-ion battery	○	○	—	—	—	—	○
205 Ah STILL Li-ion battery	—	○	○	—	○	○	○	
410 Ah STILL Li-ion battery	—	○	○	—	○	○	○	

● Standard ○ Option — Not available



STILL GmbH
Berzeliusstr. 10
22113 Hamburg
Germany
Tel.: +49 40 73 39 20 00
Fax: +49 40 73 39 20 01
info@still.de

For further information please visit
www.still.eu

STILL is certified in the following areas: Quality management, occupational safety, environmental protection and energy management.



first in intralogistics